

MOD. 160

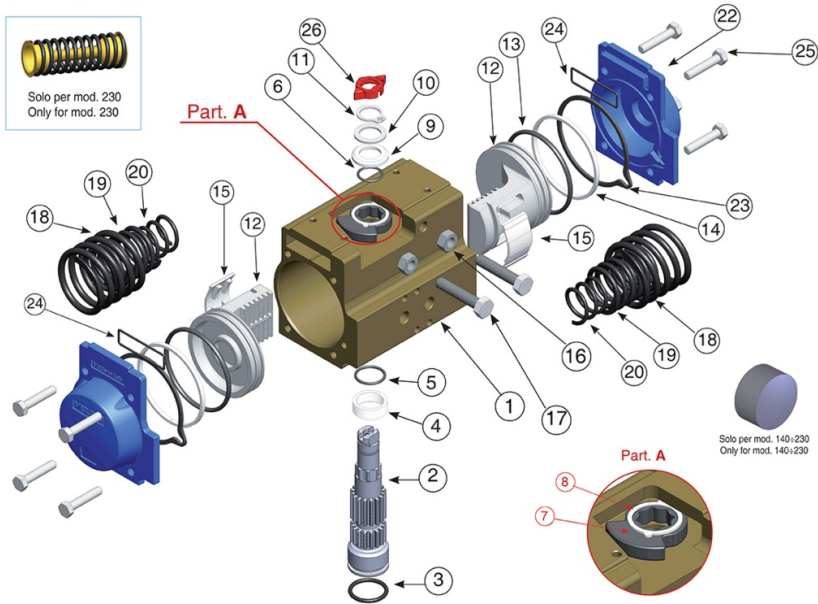

Spécifications techniques





VALIDO DA MOD. 160 A MOD. 200
 VALID FROM MOD. 160 TO MOD. 200

SET DI MOLLE
 SPRING SETS

STANDARD SET 06

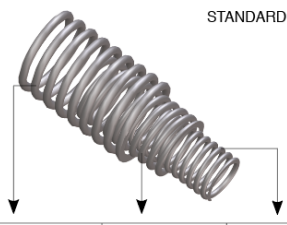

SET	MOLLA ESTERNA EXTERNAL SPRING	MOLLA CENTRALE CENTRAL SPRING	MOLLA INTERNA INTERNAL SPRING
01	-	2	-
02	2	-	-
03	1	2	-
04	2	-	2
05	2	2	-
06	2	2	2

POSITION	NOM DE LA PIÈCE	MATÉRIEL	TREATMENT	N.° PIÈCES
1	Body	Extruded aluminium	Hard anodized	1
2	Anti-blowout pinion	Steel	Nickel plated	1
• 3	O-ring	NBR/SILICONE/FKM	-	1
• 4	Spacer ring	POM/AMODEL/STANYL/PEEK	-	1
• 5	O-ring	NBR/SILICONE/FKM	-	1
• 6	O-ring	NBR/SILICONE/FKM	-	1
7	Cam	Stainless steel	-	1
8	Spacer	POM/MINLON/PTFE/PEEK	-	1
• 9	Spacer	POM/MINLON/PTFE/PEEK	-	1
10	Washer	Stainless steel	-	1
**11	Snap ring	Steel	Nickel plated	1
12	Piston	Die cast aluminium	-	2
• 13	O-ring	NBR/SILICONE/FKM	-	2
• 14	Antifriction ring	POM/AMODEL/STANYL/PTFE/MINLON/PEEK	-	2
• 15	Thrust block	POM-AMODEL-STANYL-DELFIN+MOS2/PEEK	-	2 [4]
16	Stop bolt retaining nut	Stainless steel	-	2
17	Stop bolt	Stainless steel	-	2
18	External spring	Steel	Painted	See spring setting
***19	Central spring	Steel	Painted	See spring setting
20	Internal spring	Steel	Painted	See spring setting
21	Left end cap	Die cast aluminium	Painted	1
22	Right end cap	Die cast aluminium	Painted	1
23	End cap seats	NBR/SANTOPRENE/SILICONE/FKM/ME0020-70	-	2
24	O-ring	NBR/SILICONE/FKM	-	2
25	End cap fixing screw	Stainless steel	-	8
26	Position indicator	Gomma termoplastica TPEThermoplastic rubber TPE	-	1

• Parts subject to wear

* * Reinforced series DIN 471-UNI 7436 Valid for mod. 140-160-180-200-230 only.

* * * Only for mod. 160-180-200. Only square connection at 45°

MOD	FORATURA DRILLING ISO 5211	CH	A	B	C	D	E	F	G	H	ØI	ØK	L	M	N	O	P	Q	R	S	T ISO 7/1	U	ØV
MOD. 160	F10 - F12	27	500	186	87	99	221	30	251	30	57	40	80/130	30	32	80	125	102	M10X14	M12X17	1/4"	80,5	60

Applications



FOOD & BEVERAGE



HVAC



PULP & PAPER



PAINTS & SOLVENTS



WATER TREATMENT



CHEMICAL



OEM



OIL & GAS